

## STAINLESS STEEL ACCESSORIES

### 4000 and 7000 SERIES SUNVISOR

#### INSTALLATION INSTRUCTIONS

1. Only remove plastic from bolt hole and light holes, remove remaining protective plastic coating as the last step.
2. Remove all five lights from roof.
3. Use S.S. covers, and silicone caulking to close openings in roof. (insert plugs with wire through holes, slip grommet over wire an push into holes) as per diagram below.

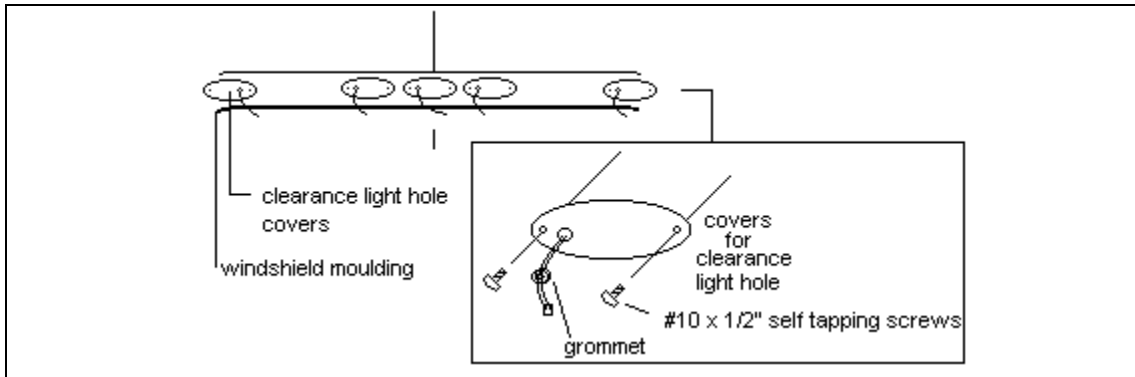

4. Mark holes for Sunvisor brackets, drill 1/8" holes, silicone holes and underside of brackets then fasten with #10 x 1/2" self tapping screws as shown below.

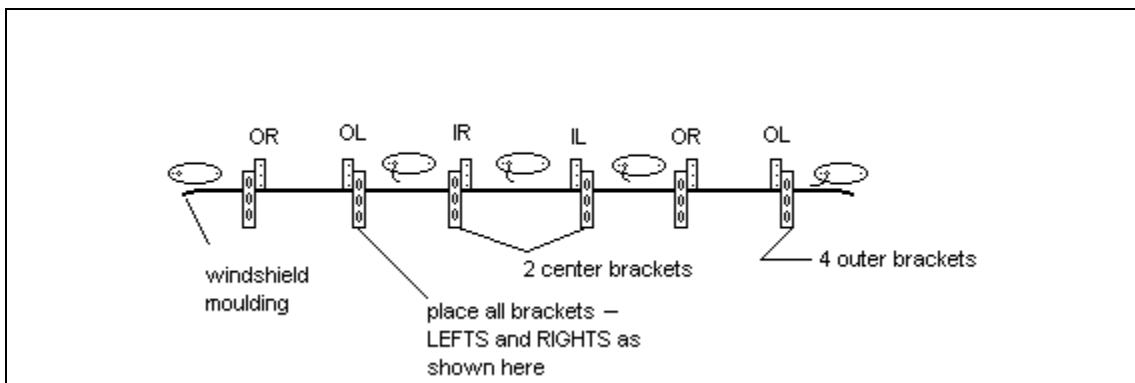
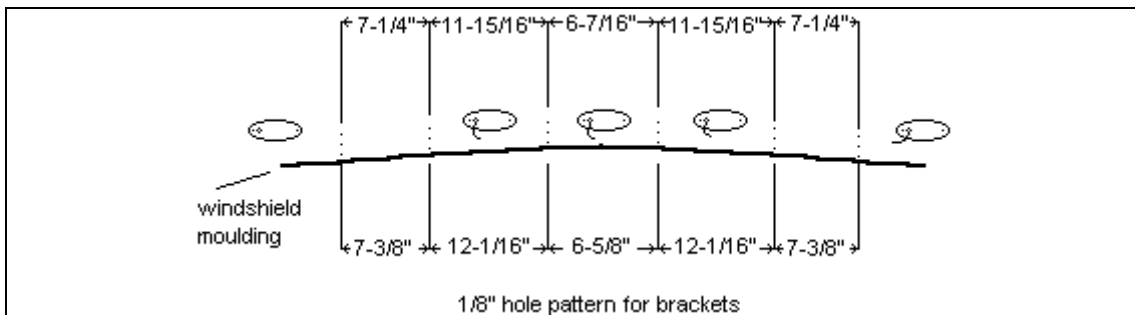

**\*NOTE Brackets are slotted for easy adjustment up and down. Tighten brackets onto sunvisor allowing some movement until last step of installation.**

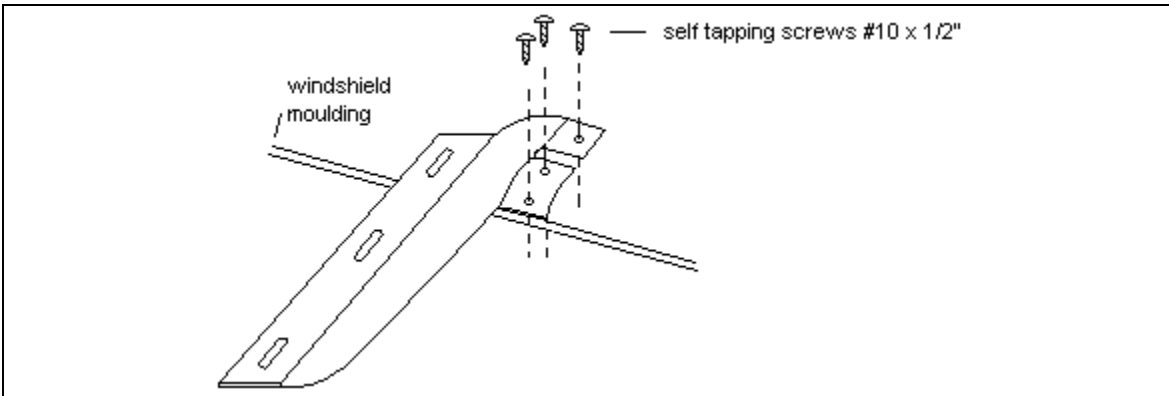

5. Install clearance lights on visor using 6-32 x 1/2" screws.
6. Place visor over top of brackets and slide ends between door gasket and A-pillar of cab.
7. Use 10-32 x 1/2" screws to fasten visor to brackets.
8. Drill 1/8" holes on ends of visor into A-pillar, use silicone to seal and tighten with #10 x 1/2" self-tapping screws to cut a thread.
9. Use silicone caulking to seal around wires and grommets.
10. Remove remaining protective plastic coating.

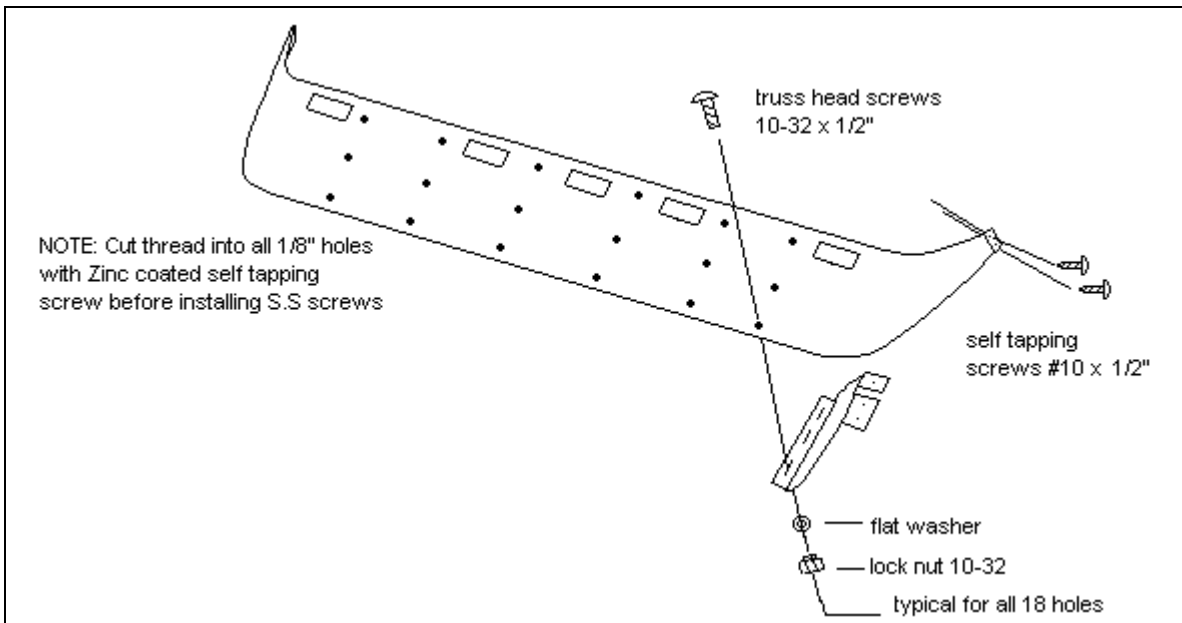

- HARDWARE :**
- |   |                          |
|---|--------------------------|
| 18 – truss head screws 10-32 x 1/2"                                 | 1 – left center bracket  |
| 18 – flat washers – 10-32   | 1 – right center bracket |
| 18 – nylon lock nuts 10-32  | 2 – left outer brackets  |
| 22 – self tapping screws #10 x 1/2"                                 | 2 – right outer brackets |
| 10 – round head screws 6-32 x 1/2"                                  | 5- grommets              |
| 10 – nylon lock nuts 6-32   | 1- silicone              |
| 1 – Zinc coated self tapping screw #10- x 1/2" (for thread cutting) |                          |