

Stainless Steel Accessories

SUNVISOR – MACK “R” MODEL

INSTALLATION INSTRUCTIONS

1. Mark holes of each bracket, equally spaced above windshield onto cab, as shown below:

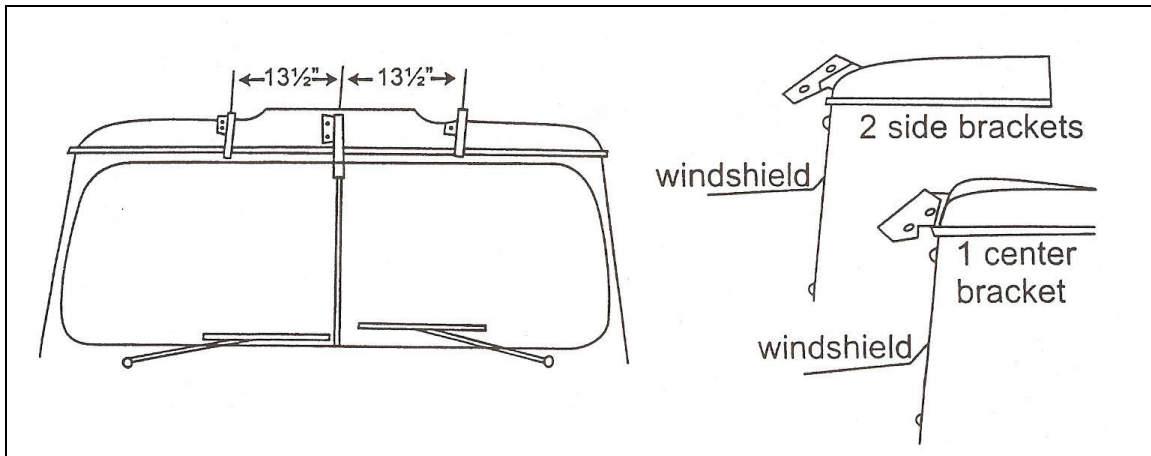

2. Drill holes with 1/8" or #30 drill bit. Cover the underside of the brackets with sealant or silicone caulking. Tighten brackets with metal screws supplied.
3. Place visor on brackets and pull tight on both ends over the eavestrough. Center of visor has to be center of cab. The bottom edge of both ends will have to be parallel to the eavestrough. Drill 1/8" holes into cab through holes in visor, use putty or silicone again and tighten.

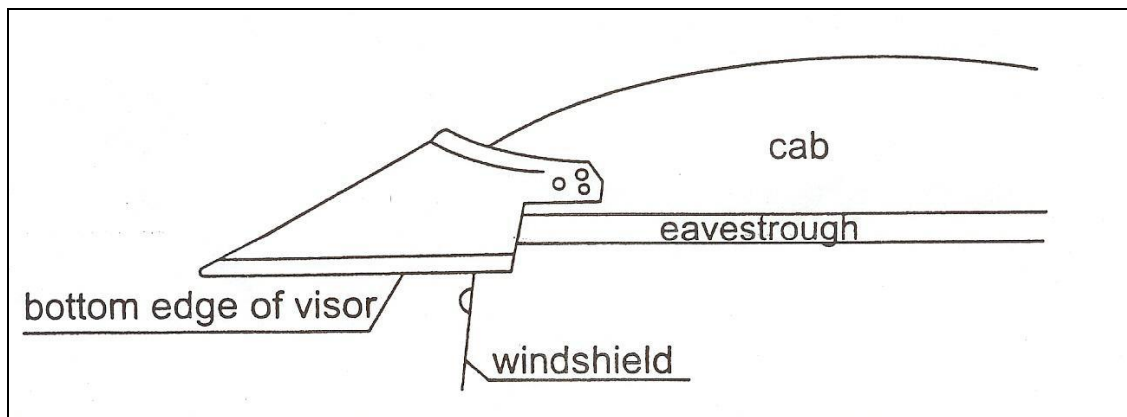

4. Adjust brackets until visor follows the shape of the cab. Drill 3 holes, 3/16" diameter, equally spaced through visor into each bracket. Use 3/16" screws and locknuts supplied, and tighten.
5. Make final adjustment and pull paper off.